

Congratulations!

You have decided to buy an LP 10 E by STEYR SPORTWAFFEN – the new dimension of match air pistols!

The world-beating air pistol with electronic trigger!

The STEYR LP 10 probably is the most successful air pistol ever, but now the LP 10 E sets another benchmark in quality and ease of handling with its electronic trigger.

- **Ball bearing trigger free from wear (training)**
- **Trigger pressure constant while releasing the shot**
- **Turbulence reduced due to new 8 duct compensator**
- **Capacity of 25.000 shots from 2 standard 1,5 V AAA batteries**
- **Redesigned housing allows more finger room**
- **Multifunctional grip adjustment can be retained by flexible electronic system**
- **Proven and patented STEYR stabilizer made out of tungsten alloy (TRIAMET)**
- **Individual adjustment within the 500 g trigger pull**

Attention:

This operator's manual should be read carefully before using the pistol!

Important measures when using arms:

All firearms are dangerous objects; they should be used and stored with utmost caution!

Always treat an unloaded weapon as if it were loaded. Never put your finger on the trigger, except when actually firing a shot. Always ensure that the weapon is pointing in a safe direction. Keeping the weapon in perfect condition ensures safety.

Weapons always have to be stored out of the reach of unauthorised persons.

TABLE OF CONTENTS

1	Technical Data	4
2	Readiness of the electronic unit	5
3	Dry firing mechanism	6
4	Cocking, loading, firing	7
5	Sight adjustment	8
5.1	Moving or exchanging the front sight	8
5.2	Rear sight adjustment	9
6	Trigger adjustment	10
6.1	Trigger blade adjustment	10
6.2	Adjusting the trigger pull force	11
6.3	Adjusting the first stage travel	12
6.4	Second stage pressure adjustment	13
7	Grip adjustment	14
8	Replacing and refilling the compressed-air cylinder	15
9	Cleaning and care	16
10	Guarantee clauses	16
11	Parts list	18

1 TECHNICAL DATA

Calibre	4.5 mm (.177)
Overall height of weapon	148 mm
Overall length of weapon	400 mm
Overall width of weapon	50 mm
Total weight of weapon	approx. 993 g
Sight length	adjustable from 316 to 365 mm
Front sight	relocatable front
Rear sight	adjustable from 1,5 to 6,5 mm
Barrel length	233 mm
Maximum filling pressure	200 bar
Electric power supply	2 standard 1,5 V AAA alkaline cells

2 READINESS OF THE ELECTRONIC UNIT

Switch pistol to ON, the red LED at the ON/OFF-switch flashes once. If this is not the case, the batteries have to be changed.

The LP 10 E is equipped with two high-quality alkaline cells. If the weapon is not turned off after usage, the batteries loose voltage more quickly and need to be changed sooner.

To change the batteries, simply remove the battery cover on the side of the grip by loosening the two screws (fig.). The electronic module has to stay in the grip, only the batteries need changing. Positioning of the batteries as shown on the bottom of the battery case.

After usage, remember to turn switch back to OFF-position.

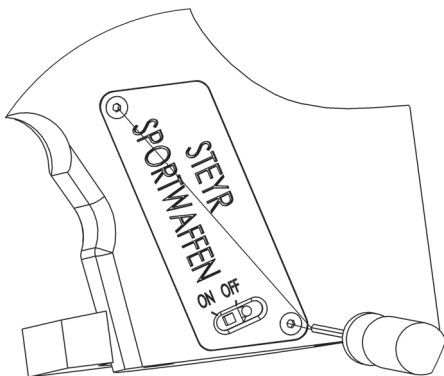

Attention: Only change batteries when electronic is switched off and weapon is unloaded!

3 DRY FIRING MECHANISM

a) Conventional dry firing (mechanical trigger)

Switch on the electronic unit. The cocking lever has to be pulled backwards to the stop (in the vertical position) and then moved forward again until you feel the first resistance. The letter "T" on the casing is still visible. The mechanism is cocked. Trigger can be tested for shooting, but no compressed air will escape.

b) Dry firing with electronic trigger

Switch on the electronic unit. The system does not need to be cocked for dry firing. Trigger can be tested for real shooting with the cocking lever not fully closed ("T" visible). No compressed air will escape.

Dry firing is also allowed during competition.

Note: Dry firing is not allowed during the Olympic final!

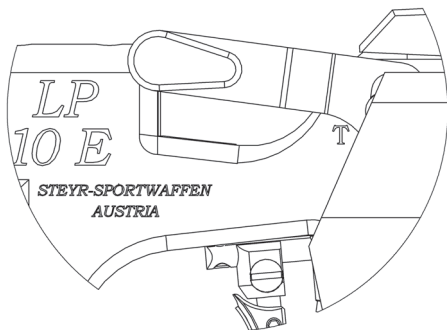

4 COCKING, LOADING, FIRING

Switch on the electronic unit. Pull back the cocking lever to the stop, this cocks the pistol and opens the loading port.

Insert a Diabolo pellet and fully close the cocking lever again. Only the letter "F" will be visible on the casing (fig.). The pistol is ready for firing.

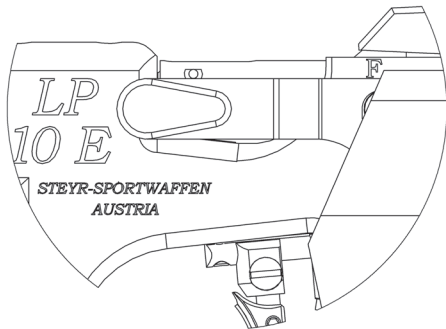

5 SIGHT ADJUSTMENT

The setscrews have to be turned as follows:

- | | | |
|-----------|---|--|
| High hit | – | turn height-adjusting screw in direction H |
| Low hit | – | turn height-adjusting screw in direction T |
| Right hit | – | turn side-adjusting screw in direction R |
| Left hit | – | turn side-adjusting screw in direction L |

One click of the side-adjusting screw changes the point of impact position by 1.2 mm at a target distance of 10 m.

5.1 Moving or exchanging the front sight

After loosening the countersunk screw the front sight can be moved backwards and forwards or removed.

5.2 Rear sight adjustment

The STEYR LP 10 E is equipped with an adjustable rear sight, this feature enables you to adjust sighting width continuously from 1,5 to 6,5 mm.

Turning screw 7 clockwise or screw 8 counter-clockwise increases the gap between the rear sight plates.

The depth of the gap is continuously adjustable from 1,8 to 2,6 mm.

For this procedure, loosen screws 9. Slide cover plate into desired position and retighten screws.

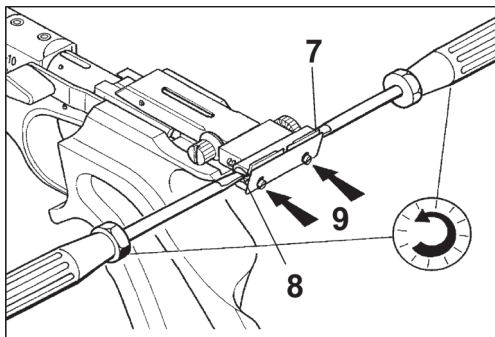

6 TRIGGER ADJUSTMENT

In the factory the trigger adjustments are set in such a way that the trigger pulling force corresponds to the ISSF-shooting rules and a smooth pulling function is ensured. Individual adaptation is possible.

PLEASE NOTE: Before making any changes on the trigger, ensure that the weapon IS UNLOADED.

6.1 Trigger blade adjustment

Loosen countersink screw A. The trigger blade can be moved in longitudinal directions.

Loosen countersink screw B. The trigger blade can be moved in height and angle.

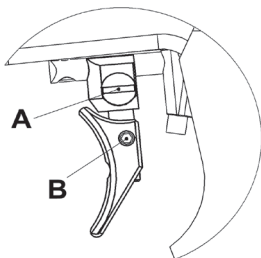

6.2 Adjusting the trigger pull force

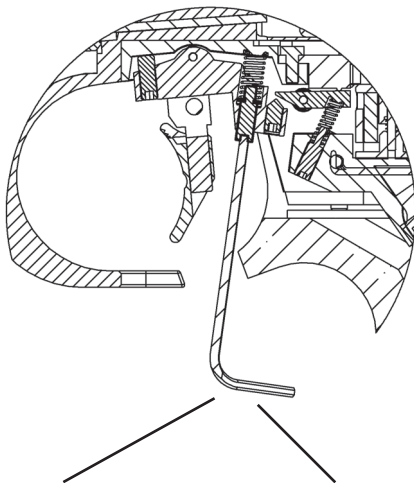

Turning the screw anticlockwise reduces the trigger pull force

Turning the screw clockwise increases the trigger pull force

6.3 Adjusting the first stage travel

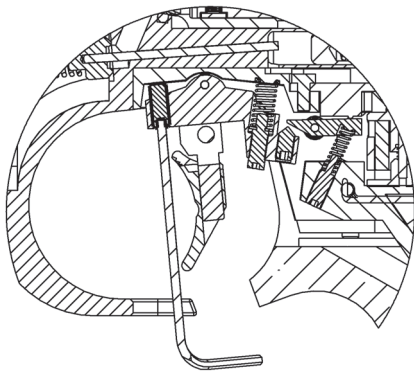

Turning the screw clockwise
reduces the dead travel

Turning the screw anticlockwise
increases the dead travel

6.4 Second stage pressure adjustment

Remove the grip.

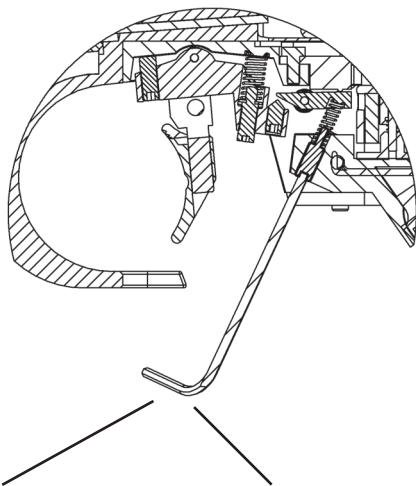

Turning screw clockwise
increases the second stage
pressure

Turning screw anticlockwise
decreases the second stage
pressure

ATTENTION: The grip is linked to the system with cables! Care must be taken not to damage these cables when removing the grip!

7 GRIP ADJUSTMENT

The grip is adjustable and pivotable to the weapon system in all directions and may be widely adapted to the shooter's stance.

Adjustment is achieved by means of the screws located at the bottom and the rear of the casing (fig.).

The grip adjustment can be done after unscrewing the grip without disconnecting the electronic unit.

The grip adjustment can be done after unscrewing the grip without disconnecting the electronic unit.

If the electronic unit is disconnected, please do not pull on the cables but use the white connector! After disconnecting the cables are pulled back into the grip by a coil spring.

To fasten the connection assembly, pull the cables a little way out of the grip and connect the electronic unit.

When you put the weapon system back into the grip, please ensure that the cables are not trapped between the casing and the grip.

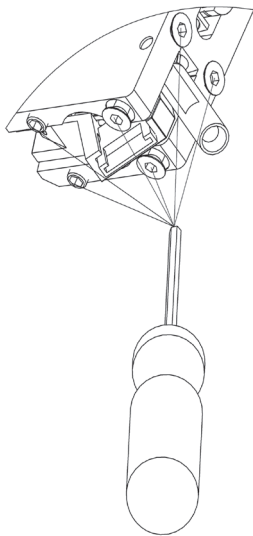

ATTENTION: At maximum offset of the grip, please ensure that the grip does not press against the pistol housing when tightening the grip securing bolt. Risk of splitting or cracking the grip!

Only remove the grip with the electronic unit switched off and weapon unloaded!

8 REPLACING AND REFILLING THE COMPRESSED-AIR CYLINDER

The compressed-air cylinders must be emptied and safely disposed of 10 years after production date. The production and disposal dates are noted on the compressed-air cylinder.

The legal requirements and rules of the respective country must be adhered to.

The compressed-air cylinder may be unscrewed and removed at any time without being emptied.

WARNING: Do not tamper with compressed-air cylinder and valve. It may cause injury!

The compressed-air cylinder is to be charged with a maximum filling pressure of 200 bar.

For recharging the cylinder proceed as follows:

- Either mount the compressed-air cylinder on a recharging bottle
- Or mount the compressed-air cylinder on a hand pump
- Or mount the compressed-air cylinder on a compressor

9 CLEANING AND CARE

In standard use the weapon operates maintenance-free and no oiling is required.

The only maintenance required is to slightly grease the O-ring in the loading port and the O-ring at the threaded adapter socket for the compressed-air cylinder with a special lubricant (acid-free silicone grease) every 1000 shots. This will increase the service life of the O-rings.

To clean the barrel shoot some dry (not greased) felt pellets or cleaning strings through the barrel (available at your dealer).

10 GUARANTEE CLAUSES

If within two years from the day of purchase any cracks or breaks should occur on this weapon that are due to material failure we undertake the repair of the defective parts free of charge (except breakage or cracking of the stock/pistol or O-rings).

Guarantee will be given by either replacing or repairing the weapon or parts of it at our sole discretion. **The guarantee is only valid if the fully completed guarantee card is returned immediately after purchasing the weapon.**

No guarantee claims will be accepted by the STEYR Sportwaffen GmbH if:

- a) the weapon has been damaged or destroyed by force majeure or environmental influences;
- b) in case of damages/defects having been caused by improper treatment or handling or by lack of care;
- c) if the weapon has been repaired, machined or altered by any person or workshop other than an authorised STEYR Sportwaffen GmbH workshop.

Claims for damages and product liability:

No claims for direct or indirect damages will be accepted.

Liability for material damages resulting from the product liability law, BGBL 99/1988, as well as any product liability claims that could be derived from other provisions are excluded.

The object of purchase warrants only that type of safety which may be expected in accordance with the homologation rules, service manual, manufacturer's instructions as well as any other pertinent information received.

The above clauses govern the full customer/manufacturer relationship with our company. Any addition claims, in particular for any kind of damages or losses caused by the weapon or its use, are excluded.

Guaranteed STEYR Sportwaffen accuracy:

Our barrels are made from high quality barrel steel and are produced according to the latest findings in barrel production technology. Our weapons are well known for their outstanding accuracy. However, the accuracy of a weapon depends on several factors; one of the most important factors is the ammunition used. Not every ammunition "fits" every barrel equally good.

If you follow our suggestion, we guarantee that you will achieve outstanding accuracy with your new product.

To check precision with a clamped weapon, it is advisable to clamp the pistol around the area of the trigger guard.

11 PARTS LIST

Item	Designation
1	Barrel
2	Barrel casing, assembly.
2,1	Barrel casing
2,2	Compensator
2,3	Hexagon socket set screw
2,4	Hexagon socket set screw
3	Cocking lever
4	Front sight 4.5 mm
5	Countersunk screw
6	Barrel weight assembly.
7	O-Ring 6 x 2
8	Barrel weight
9	Screw lock
10	Hexagon socket set screw
11	Hexagon socket set screw
12	Casing
13	O-ring 18 x 2
14	Hexagon socket set screw
15	Cam
16	Cam screw
17	Pressure spring
18	Valve assembly
19	Hammer
20	Set screw V0
21	Threaded bushing
22	Cocking lever
23	Cocking lever handle
24	Stop screw
25	Parallel pin
26	Hex. Socket countersunk head screw
27	Grip locking rod
28	Sight yoke
29	Pressure reducing valve
29,1	Piston assembly
29,2	Adapter for pressure reducing valve
29,3	Housing for pressure reducing valve

Item	Designation
29,4	Adjusting screw for pressure reducing valve
29,5	Cover for pressure reducing valve
29,6	Guiding sleeve
29,7	O-ring
29,8	O-ring
29,9	O-ring
29,10	O-ring
29,11	Connecting screw
29,12	Disc spring
30	Mounting screw
31	Sight carrier
32	Rear sight plate right
33	Rear sight plate left
34	Spindle, right
35	Spindle, left
36	Fixing clamp
37	Cover plate
38	Slotted cheese head screw
39	Sight yoke
40	Sliding block
41	Height adjustment screw
42	Spring for sight carrier
43	Spring to sight yoke
44	Catch spring
45	Ball
46	Circlip
47	Lateral adjusting screw
48	Sight plate
49	Screw for sight plate
50	Washer
51	Spring
52	Pressure spring
53	First stage pressure spring
54	Hexagon socket set screw
55	Trigger blade carrier screw
55,1	Trigger blade carrier
55,2	Circlip
55,3	Hexagon socket set screw

Item	Designation
55,4	First stage pressure adjusting screw
55,5	Hexagon socket set screw
56	Hexagon socket set screw
57	Parallel pin
58	Trigger complete
58,1	Trigger blade carrier
58,2	Trigger blade
58,3	Slotted raised countersunk head screw
59	Bolt
60	Stabilizer
61	Catch lever
62,1	Bolt roller
62,2	Bolt axle
63	Guide ring
64	Pressure spring
65	Parallel pin
66	Ball
67	Hexagon socket set screw
68	Spring
69	Hexagon socket set screw
70	Sight carrier assembly
71	O-Ring 5 x 1,5
72	Propellant cylinder compressed-air
73	Grip complete
73,1	Grip
73,2	Palm shelf
73,3	Label
73,4	Slotted cheese head screw
73,5	Grip clamp
73,6	Threaded insert
73,7	Rest plate
73,8	Grip plate
73,9	Slotted cheese head screw
73,10	Washer
74	Trigger unit
74,1	Trigger casing
74,2	Hammer complete
74,3	Rocker

Item	Designation
74,4	Parallel pin
74,5	Second stage pressure screw
74,6	Fixing screw
74,7	Parallel pin
74,8	Ball bearing
75	Battery
76	Electronic unit
77	Fill adapter complete
77,1	Fill adapter
77,2	O-Ring 13 x 2
78	Screw
79	Bolt complete
80	Notch
81	Pressure spring
82	Extension spring