

Attention:

This operator's manual should be read carefully before using the pistol!

Important measures when using arms:

All firearms are dangerous objects, they should be used and stored with utmost caution!

Always treat an unloaded weapon as if it were loaded. Never put your finger on the trigger, except when actually firing a shot. Always ensure that the weapon is pointing in a safe direction. Keeping the weapon in perfect condition ensures safety.

Weapons always have to be stored out of the reach of unauthorised persons, particularly children and juveniles.

TABLE OF CONTENTS

1	Technical data	26
2	Dry firing mechanism	27
3	Cocking, Loading, firing	27
4	Sight adjustment	28
4.1	Moving or exchanging the front sight.....	28
4.2	Rear sight adjustment	29
5	Trigger adjustment	30
5.1	Trigger blade adjustment	30
5.2	Adjusting the trigger stop	31
5.3	Adjusting the trigger pull force	32
5.4	Adjusting the first stage travel	33
5.5	Second stage pressure adjustment	34
5.6	Rear adjustment.....	35
6	Grip readjustment	36
7	Replacing and refilling the compressed-air cylinder	37
8	Cleaning and care	38
9	Guarantee clauses	39
10	Illustration of spare parts	41

1 TECHNICAL DATA

Calibre	4.5 mm (.177)
Overall height of weapon	148 mm
Overall length of weapon	390 mm
Overall width of weapon	50 mm
Total weight of weapon	ca. 905 g
Sight length	311 - 335 mm adjustable
Front sight	relocatable front
Rear sight.....	Rear sight either 3.5 or 4 mm
Barrel length.....	228 mm
Maximum filling pressure	200 bar

2 DRY FIRING MECHANISM

The cocking lever is pulled backwards (to a vertical position) and then moved forward again until you feel the first resistance. The letter "T" on the casing is still visible.

The mechanism is cocked. Trigger characteristics are realistic and can be tested for real shooting but no compressed air will escape.

3 COCKING, LOADING, FIRING

Pull back the cocking lever to the stop, this cocks the pistol and opens the loading port.

Insert a Diabolo pellet and fully close the cocking lever again. Only the letter "F" will be visible on the casing. The pistol is ready for firing.

4 SIGHT ADJUSTMENT

The setscrews have to be turned as follows:

- High hit - turn height-adjusting screw in direction H
- Low hit - turn height-adjusting screw in direction T
- Right hit - turn side-adjusting screw in direction R
- Left hit - turn side-adjusting screw in direction L

One click of the side-adjusting screw changes the point of impact position by 1.2 mm at a target distance of 10 m.

4.1 Moving or exchanging the front sight:

After loosening the countersunk screw the front sight can be moved backward and forward.

4.2 Rear sight adjustment:

The rear sight plate has two notches, one is 3.5 mm, the other is 4 mm.

To change the two adjustments, loosen countersunk screw, reset the rear sight plate and fasten countersunk screw.

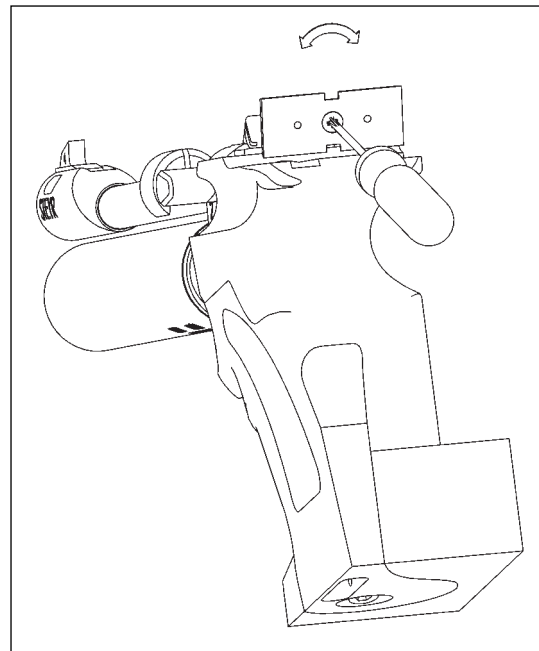

5 TRIGGER ADJUSTMENT

In the factory the trigger adjustments are set in such a way that the trigger pulling force corresponds to the ISSF-shooting rules and a smooth pulling function is ensured. Individual adaptation is possible.

PLEASE NOTE: Before making any changes on the trigger, ensure that the weapon IS UNLOADED.

5.1 Trigger blade adjustment:

Loosen countersunk screw. The trigger blade may then be moved either to the left or to the right and moved in a longitudinal direction.

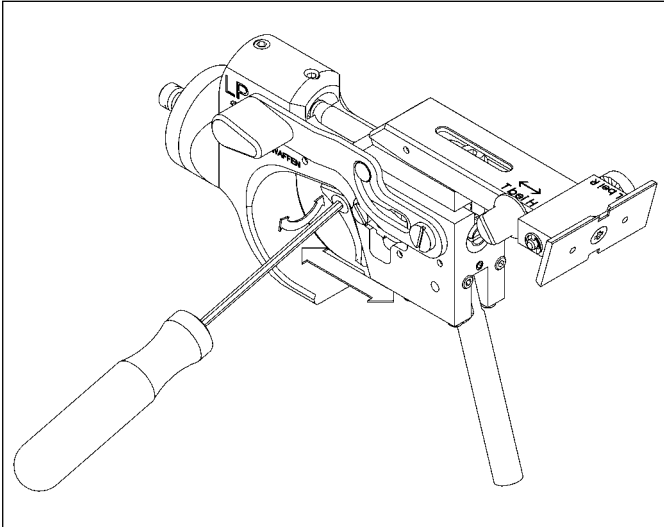

5.2 Adjusting the trigger stop:

Turning the screw clockwise shortens the "aftertravel" of the trigger blade after shot release. Turning the screw anticlockwise lengthens the "aftertravel" after shot release.

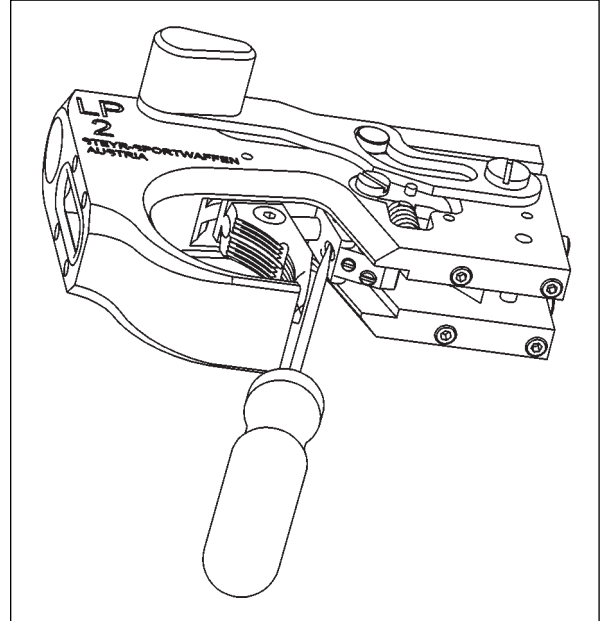

PLEASE NOTE: A too close adjustment may cause unsteady trigger action.

5.3 Adjusting the trigger pull force:

Turning the screw anticlockwise reduces the trigger pull force. Turning the screw clockwise increases the trigger pull force.

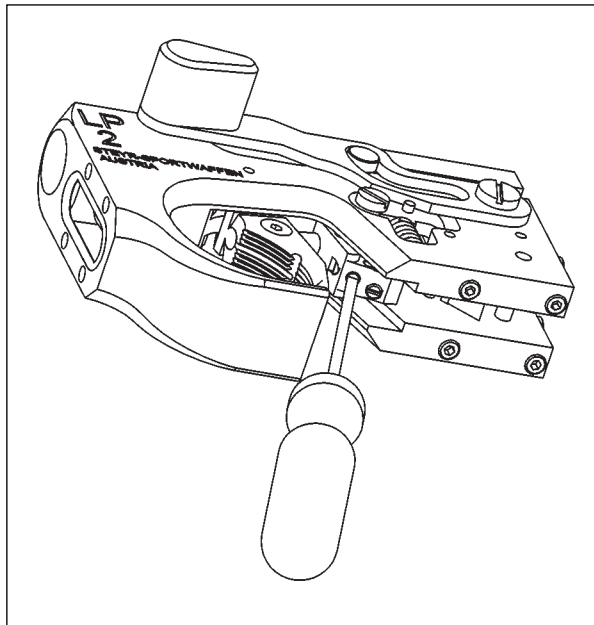

5.4 Adjusting the first stage travel:

To reduce first stage travel, first loosen the triggerstop screw counterclockwise a few turns. Turning the screw clockwise reduces the dead travel. Turning the screw anticlockwise increases the dead travel.

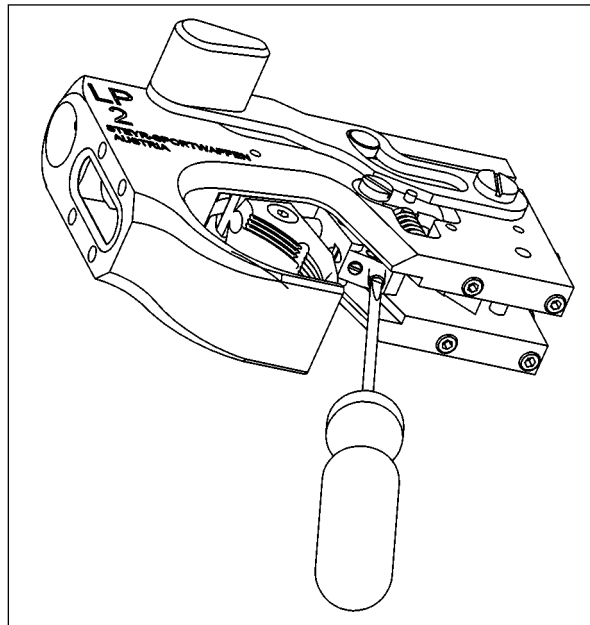

5.5 Second stage pressure adjustment:

Remove grip by loosening the cheese head screw on bottom side of grip. Turning screw clockwise increases the second stage pressure. Turning screw anticlockwise decreases the second stage pressure.

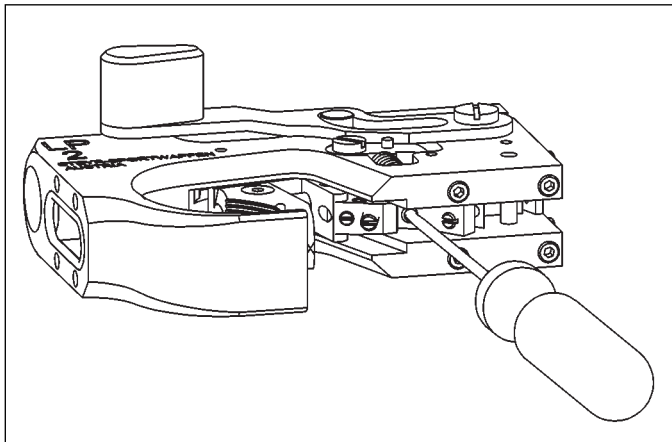

5.6 Rear adjustment:

The bridging of the rear between trigger rear and trigger lever is exactly adjusted by the factory and **must not be changed**. The screw therefore is sealed with red lacquer.

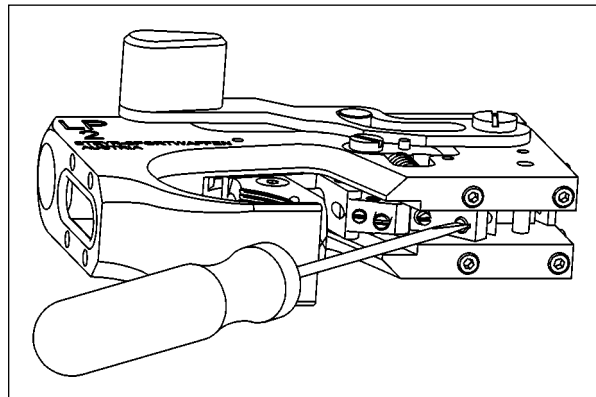

6 GRIP ADJUSTMENT

The grip is adjustable and pivotable to the weapon system in all directions and may be widely adapted to the shooter's stance. For this purpose the grip has to be removed. Adjustment is achieved by means of the screws located at the bottom and the rear of the casing.

PLEASE NOTE: The two countersunk screws on the rear of the casing must always protrude at least 2.5 mm, to assure the velocity screw is clear of the grip.

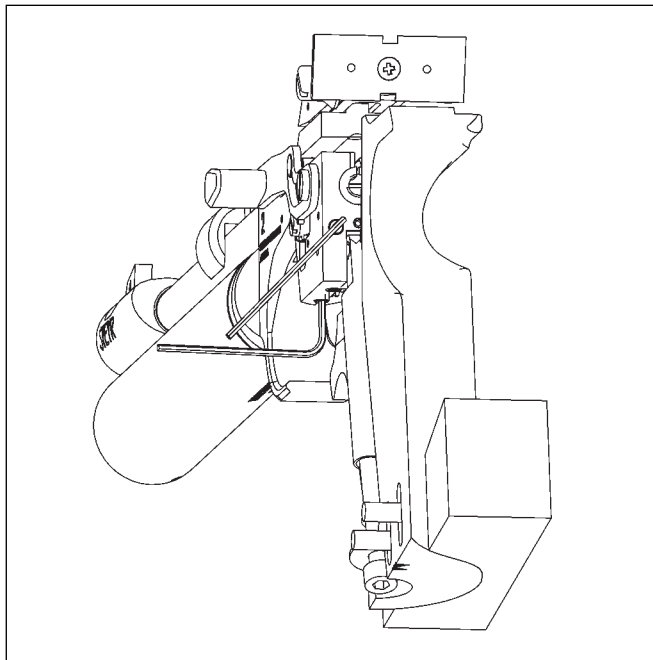

7 REPLACING AND REFILLING THE COMPRESSED-AIR CYLINDER

The legal requirements and rules of the respective country must be adhered to. Compressed-air cylinders have to be inspected after 10 years exclusively by the manufacturer. It is the responsibility of the customer to return the cylinder to the manufacturer. For reasons of safety the magazine has to be removed before exchanging the compressed-air cylinder. The compressed-air cylinder may be unscrewed and removed at any time without being emptied.

WARNING! Do not tamper with compressed-air cylinder and valve. It may cause injury!

The compressed-air cylinder is to be charged with a maximum filling pressure of 200 bar.

For recharging the cylinder proceed as follows:

- either mount the compressed-air cylinder on a recharging bottle
- or mount the compressed-air cylinder on a hand pump
- or mount the compressed-air cylinder on a compressor

8 CLEANING AND CARE

In standard use the weapon operates maintenance-free and no oiling is required.

The only maintenance required is to slightly grease the O-ring in the loading port and the O-ring at the threaded adapter socket for the compressed-air cylinder with a special lubricant (acid-free silicone grease) every 1000 shots. This will increase the service life of the O-rings.

To clean the barrel shoot some dry (not greased) felt pellets through the barrel.

9 GUARANTEE CLAUSES

If within one year from the day of purchase any cracks or breaks should occur on this weapon that are due to material failure we undertake repair the defective parts free of charge. (except breakage or cracking of the stock/pistol grip or O-rings).

Guarantee will be given by either replacing or repairing the weapon or parts of it at our sole discretion. **The guarantee is only valid if the fully completed guarantee card is returned immediately after purchasing the weapon.**

No guarantee claims will be accepted by the Steyr-Sportwaffen GmbH if:

- a) the weapon has been damaged or destroyed by force majeure or environmental influences;
- b) in case of damages/defects having been caused by improper treatment, or handling or by lack of care.
- c) if the weapon has been repaired, machined or altered by any person or workshop other than an authorised Steyr Sportwaffen GmbH workshop.

Claims for damages and product liability:

No claims for direct or indirect damages will be accepted. Liability for material damages resulting from the product liability law, BGBL 99/1988, as well as any product liability claims that could be derived from other provisions are excluded.

The object of purchase warrants only that type of safety which may be expected in accordance with the homologation rules, service manual, manufacturer's instructions as well as any other pertinent information received.

The above clauses govern the full customer/manufacturer relationship with our company. Any additional claims, in particular for any kind of damages or losses caused by the weapon or its use, are excluded.

Guaranteed Steyr Sportwaffen accuracy:

Our barrels are made from high quality barrel steel and are produced according to the latest findings in barrel production technology. Our weapons are well known for their outstanding accuracy. However, the accuracy of a weapon depends on several factors; one of the most important factors is the ammunition used. Not every ammunition "fits" every barrel equally good.

If you follow our suggestion, we guarantee that you will achieve outstanding accuracy with your new product. Claims regarding inconsistent accuracy must be reported to us in written within 20 (twenty) days after purchasing the weapon.

To check precision with a clamped weapon, it is advisable to clamp the pistol around the area of the trigger guard.

10 PARTS LIST LP 2

Item	Designation
1	Housing
2	Bolt
3	Trigger Sear
4	Trigger
5	Barrel
6	Threaded bushing
7	Set screw V0
8	Grip locking rod
9	Screw
10	Compensator
11	Housing pressure reducing valve
12	O-ring
13	O-ring
14	Screwpressure reducing valve
15	Guiding sleeve
16	Cover
17	Screw
18	Piston
20	O-ring
21	Disc spring
22	Filter
23	Adapter for pressure reducing valve
24	O-ring
25	Compressed air cylinder body
26	O-ring
27	Valve body
28	Valve head
29	Pressure spring
30	Supporting ring
31	O-ring
32	O-ring
33	Cylinder valve tappet
35	Pressure gage
37	Bolt roller
38	Compensator cone
39	Front sight
40	Cam

Item	Designation
41	Screw
42	Screw
43	Screw
44	Slotted set screw
45	Parallel pin
46	Parallel pin
47	Pressure spring
48	Slotted set screw
49	Nut
50	Screw
51	O-ring
52	Slotted set screw
53	First stage pressure spring
54	Pressure spring
55	Pressure spring
56	Pressure spring
57	Screw
58	Lateral adjusting screw
59	Sight yoke
60	Sliding block
61	Height adjusting screw
62	Sight carrier
63	Rear sight plate
64	Sight plate
65	Slotted cheese head screw
66	Washer
67	Pressure spring
68	Pressure spring
69	Ball
70	Catch spring
71	Washer
72	Parallel pin
73	Trigger blade carrier
74	Slotted set screw
76	Screw
78	Slotted set screw
79	Trigger lever
81	Cocking lever handle

Item	Designation
82	O-ring
83	Striking lever lock
84	Slotted set screw
85	Barrel weight
86	Slotted set screw
87	Grip
88	Rest plate
89	Distance plate
91	Grip weight
92	Slotted cheese head screw
93	Washer
94	O-ring
95	Cocking lever
96	O-ring
98	Valve assy
99	Pressure reducing valve
100	Compressed air cylinder

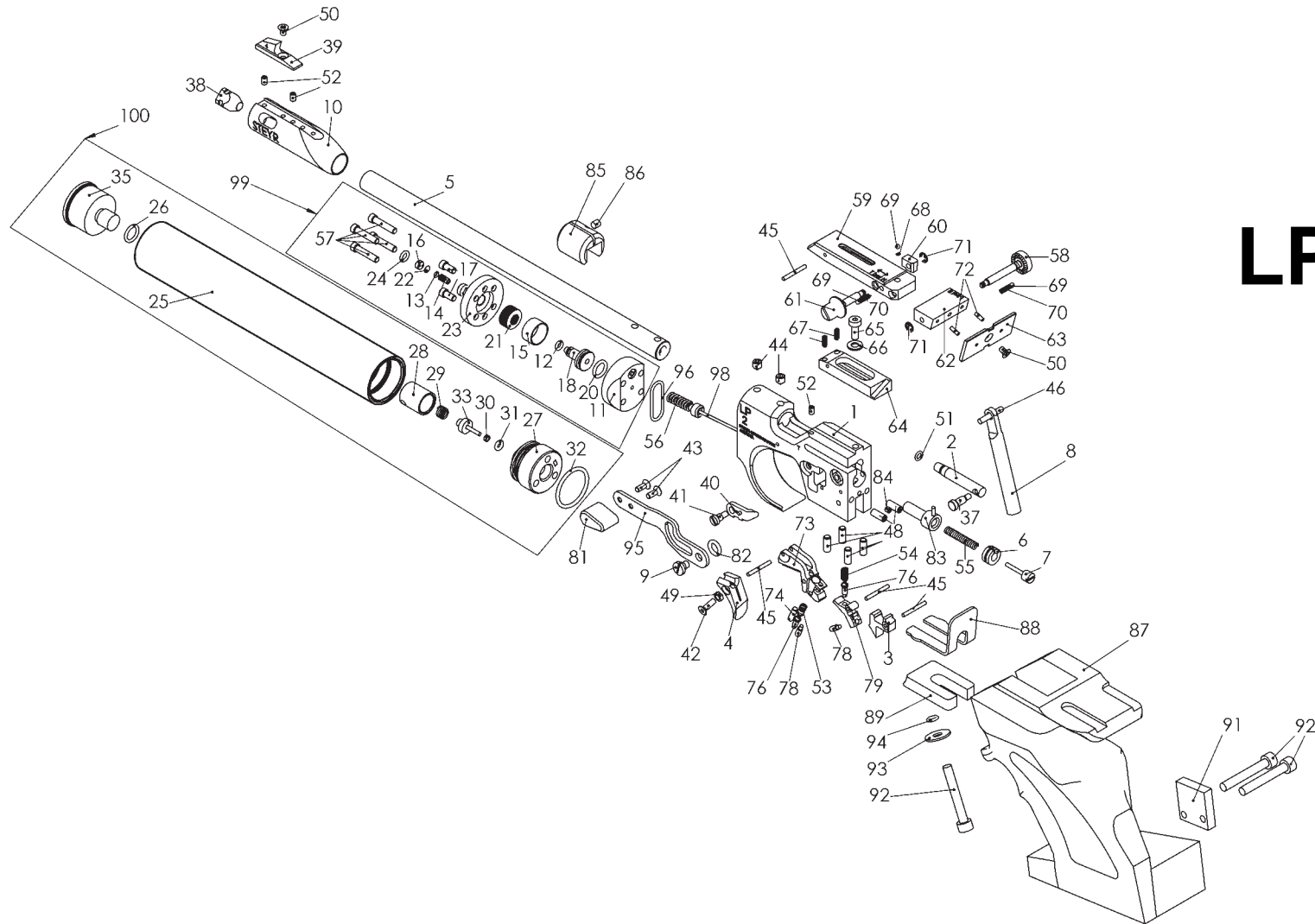

LP-2