



# LP SILHOUETTE

Bedienungsanleitung  
Operator's manual



Abbildungen mit optionalem  
Zubehör



**SPORTWAFFEN**

**Attention:**

This operator's manual should be read carefully before using the air pistol.

**Important measures when using arms:**

All firearms can be dangerous; they should be used and stored with utmost caution!

Always treat an unloaded weapon as if it were loaded. Never put your finger on the trigger, except when actually firing a shot. Always ensure that the weapon is pointing in a safe direction. Keeping the weapon in perfect condition ensures safety.

Weapons must always be stored out of the reach of unauthorized persons.

**TABLE OF CONTENTS**

<b>1</b>	<b>Technical data</b>	18
<b>2</b>	<b>Filling the magazine</b>	19
<b>3</b>	<b>Cocking, inserting the magazine (loading), firing</b>	20
<b>4</b>	<b>Removing the magazine (unloading)</b>	21
<b>5</b>	<b>Trigger adjustment</b>	22
5.1	Trigger blade adjustment	22
5.2	Adjusting the trigger stop	23
5.3	Adjusting the trigger pull force	23
5.4	Adjusting the first stage travel	24
<b>6</b>	<b>Grip adjustment</b>	25
<b>7</b>	<b>Replacing and refilling the compressed air cylinder</b>	26
<b>8</b>	<b>Cleaning and care</b>	26
<b>9</b>	<b>Guarantee clauses</b>	27
<b>10</b>	<b>Parts list</b>	29

## 1 TECHNICAL DATA

Calibre	4.5 mm (.177)
Overall height of weapon	145 mm
Overall length of weapon	430 mm
Overall width of weapon	56 mm
Total weight of weapon	1.400 g
Barrel length	400 mm
Maximum filling pressure	200 bar

## 2 FILLING THE MAGAZINE

Place pellets one after the other, as shown, into the magazine chamber.

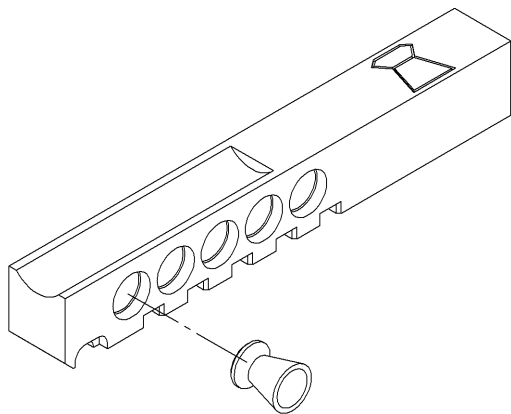

### 3 COCKING, INSERTING THE MAGAZINE (LOADING), FIRING

The magazine may be inserted only when the pistol is cocked. It is impossible to insert the magazine the wrong way because the recess on the magazine and the spring sleeve in the magazine housing must match.

Process:

- 1.) The system is cocked if the cocking lever is pulled fully to the rear.

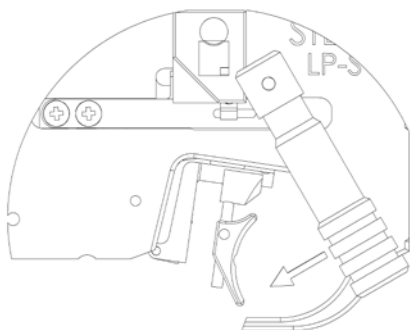

- 2.) The filled magazine has to be fully inserted from the right to the left in the magazine port. The pistol is now ready for firing.

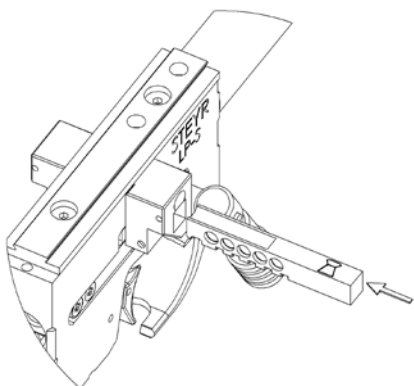

#### 4 REMOVING THE MAGAZINE (UNLOADING)

The magazine is empty when all five shots have been fired but the system is still cocked. The magazine catch located at the bottom right of the magazine tube has to be pressed for the magazine to be removed. If you try to fire a sixth shot, the system has to be cocked again in order to be able to remove the magazine.

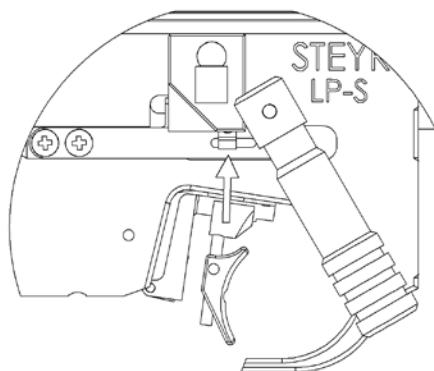

**PLEASE NOTE:** The magazine may also be removed without emptying it. When pressing the magazine catch, ensure the magazine, which is under spring pressure, does not fly out.

## 5 TRIGGER ADJUSTMENT

**PLEASE NOTE:** Before making any changes to the trigger, ensure that the weapon is **UNLOADED**.

### 5.1 Trigger blade adjustment:

The trigger blade may be moved either to the left or to the right and moved in a longitudinal direction.

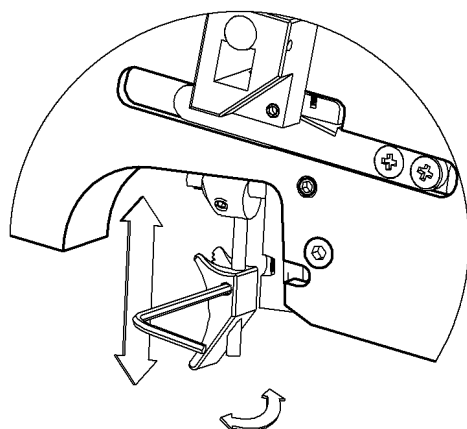
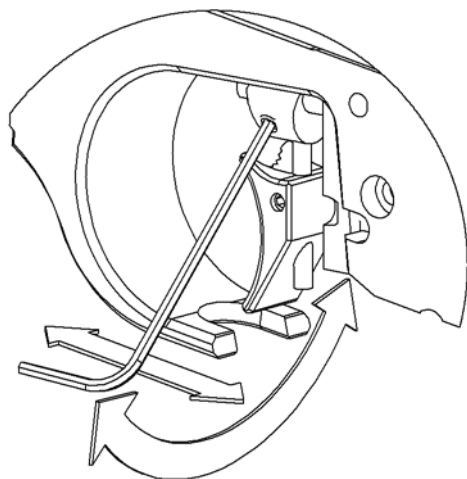



## 5.2 Adjusting the trigger stop:

Turning the screw clockwise (as shown in the illustration) shortens the „after travel“ of the trigger blade after shot release. Turning the screw anticlockwise lengthens the “after travel” after shot release.

**PLEASE NOTE:** Too fine adjustment of the trigger Stopp may cause inconsistent trigger weight and release.

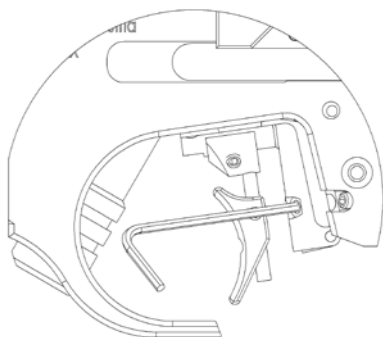

## 5.3 Adjusting the trigger pull force:

Turning the screw anticlockwise reduces the trigger pull force. Turning the screw clockwise increases the trigger pull force.

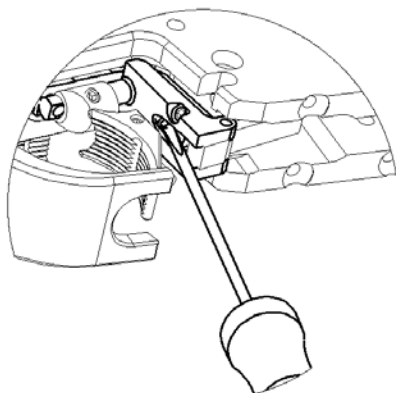

#### 5.4 Adjusting the first stage travel:

Turning the screw clockwise reduces the dead travel. Turning the screw anticlockwise increases the dead travel.

**PLEASE NOTE:** Too fine adjustment of the first stage travel may cause inconsistent trigger weight and trigger release.

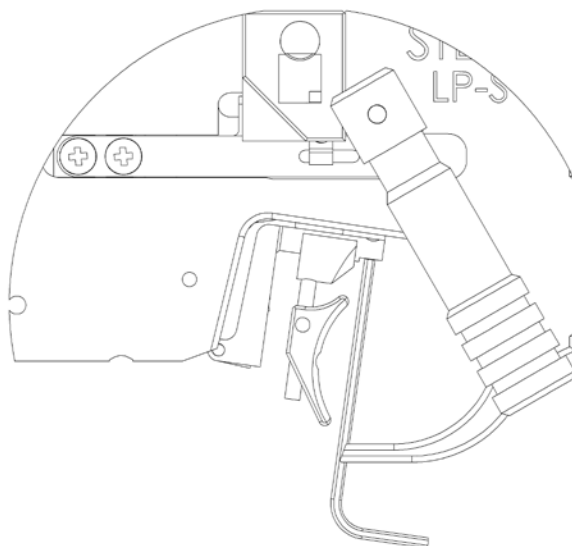

## 6 GRIP ADJUSTMENT

The grip is adjustable and pivotable in all directions of the weapon system and may be widely adapted to the shooter's stance. For this purpose the grip has to be removed.

Adjustment is achieved by means of the screws located at the bottom and the rear of the casing.

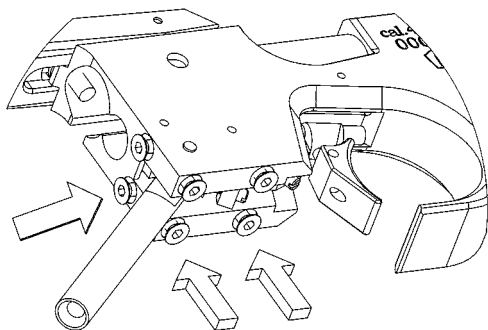

**PLEASE NOTE:** The two countersunk screws on the rear of the casing must always protrude at least 2.5 mm to assure the velocity screw is clear of the grip.

## 7 REPLACING AND REFILLING THE COMPRESSED-AIR CYLINDER

The compressed-air cylinders must be deflated and disposed 10 years after production date. The production and disposal dates are noted on the compressed-air cylinder. The legal requirements and rules of the respective country must be adhered to.

The compressed-air cylinder may be unscrewed and removed at any time without being emptied.

**WARNING: Do not tamper with compressed-air cylinder and valve. It may cause injury!**

The compressed-air cylinder is to be charged with a maximum filling pressure of 200 bar.

For recharging the compressed-air cylinder, mount it::

- o on a recharging bottle
- o on a hand pump
- o on a compressor

## 8 CLEANING AND CARE

In standard use the weapon operates maintenance-free and no oiling is required.

The only maintenance required is to slightly grease the O-ring in the loading port and the O-ring at the threaded adapter socket for the compressed-air cylinder with a special lubricant (acid-free silicone grease) every 1000 shots. This will increase the service life of the O-rings.

To clean the barrel shoot some dry (not greased) felt pellets or cleaning strings through the barrel (available at your dealer).

## 9 GUARANTEE CLAUSES

If within two years from the day of purchase any cracks or breaks should occur on this weapon that are due to material failure, we undertake repair of the defective parts free of charge (except breakage or cracking of the stock/pistol grip or O-rings).

Guarantee will be given by either replacing or repairing the weapon or parts of it at our sole discretion. **The guarantee is only valid if the fully completed guarantee card is returned immediately after purchasing the weapon.**

**No guarantee claims will be accepted by the STEYR Sportwaffen GmbH if:**

- a) the weapon has been damaged or destroyed by force majeure or environmental influences;
- b) in case of damages/defects caused by improper treatment or handling or by lack of care;
- c) if the weapon has been repaired, machined or altered by a person or workshop other than an authorised STEYR Sportwaffen GmbH workshop.

### **Claims for damages and product liability:**

No claims for direct or indirect damages will be accepted.

Liability for material damages resulting from the product liability law, BGBL 99/1988, as well as any product liability claims that could be derived from other provisions are excluded.

The object of purchase warrants only that type of safety which may be expected in accordance with the homologation rules, service manual, manufacturer's instructions as well as any other pertinent information received.

The above clauses govern the full customer/manufacturer relationship with our company. Any additional claims, in particular for any kind of damages or losses caused by the weapon or its use, are excluded.

**Guaranteed STEYR Sportwaffen accuracy:**

Our barrels are made of high quality barrel steel and are produced according to the latest findings in barrel production technology. Our weapons are well known for their outstanding accuracy. However, the accuracy of a weapon depends on several factors; one of the most important factors is the ammunition used. Not every ammunition “fits” every barrel equally good.

If you follow our suggestion, we guarantee that you will achieve outstanding accuracy with your new product.

To check precision with a clamped weapon, it is advisable to clamp the pistol around the area of the trigger guard.

**10 PARTS LIST**